

KRACHT



Transfer Gear Pumps

Applications from A to Z

Applications

Machine-building industry
 Manufacture of apparatus
 Filling stations
 Waste oil
 - disposal
 - transport
 - treatment

Coating machines

Printing machines
 Metering systems

Heavy electrical machines

Paint industry
 Filter systems

Generator construction
 Transmission building
 Plain metal bearing production
 Rubber and tire manufacturing

Engine construction
 Refrigerators
 PUR machinery

Marine engine construction
 Lubricating oil systems
 Lubricant manufacturers

Turbine construction
 Tank plant construction
 Metal-forming machines

Compressors
 Vacuum machinery

Heat transfer systems
 Machine tools

Centrifuge construction

Suitable fluids

Waste oils
 Soluble oils
 Diesel oils
 Printing inks

Emulsions
 Dyes
 Fats
 Antifreeze

Gear oils

Resins
 Hardening oils
 Fuel oils, L, EL, H
 Hydraulic fluids

Isocyanate

Adhesives
 Plastics

Engine oils
 Nitrocellulose lacquers
 Paraffins
 Polyols
 Lubricating oils
 Cutting oils
 Heavy oils
 Heat transfer media
 Processing oils
 Waxes
 Rolling oils
 Drawing compounds



Contents

Technical Data

Contents	Page
Applications	2
Contents	3
Description	4
Characteristics	5
Technical Data, Type Code	6
Tables: Discharge flow and power consumption	7
Determination of power consumption	8

Dimension Sheets

Contents	Page
Flange-mounting pumps Nominal displacement 4 – 25	9
Flange-mounting pumps Nominal displacement 32 – 80	10
Foot mounted pump Nominal displacement 4 – 25	11
Foot mounted pump Nominal displacement 32 – 80	12
Accessory couplings	13
Motor-Pump Assemblies Nominal displacement 4 – 25	14 – 15
Motor-Pump Assemblies Nominal displacement 32 – 80	16 – 17
Accessory connections	18
Accessory VC Volume counter and Elektronik	19

Descriptions

Product features

KF gear pumps are used for pumping a wide variety of fluids.

KF gear pumps are distinguished especially by their wide range of variants which are assembled as required on the modular principle and also permit subsequent upgrade. The pumps are also suitable for media with low lubricating properties.

The standard housing sections are of grey cast iron. The gear units are manufactured from high-strength case-hardening steel, hardened and mounted in special multi-compound plain bearing bushes.

The standard drive shaft is sealed by rotary shaft lip-type seal.

All pump sizes incorporate helical tooth system. This feature, combined with special gear geometry, results in extremely low noise levels and reduced pressure pulsation.

Variants:

- Sealing of the drive shaft
- Rotary shaft lip-type seal
- Double rotary shaft lip-type seal (Quench)
- Mechanical seal
- Outboard bearing to take up input drive-side radial load
- Pressure relief valve as safety valve for pump and system
- Uniform discharge flow direction with changing direction of rotation by means of flange-mounting valve combination (universal device).

Special design

Various shafts ends and gear units, as well as flange mounted versions, bearing alternatives, multi-stage pump combinations for your special application are available on request.

Our Sales engineers will be pleased to advise you.

Accessories:

- Connecting flanges
- Couplings
- Bell housings

Operating notes

- The fluids should ensure a certain minimum lubricating properties, should not contain solids and should be chemically compatible.
- Avoid dry operation.
- The pumps may only be operated in the specified direction of rotation, as otherwise the shaft seal will be destroyed.
- In order to prevent excessive overpressure, a safety valve should be provided in the system or on the pump.
- The pressure relief valve attached to the pump may only be used as safety valve for short-term operation.
- To drain off a partial discharge flow over a prolonged period, a separate pressure relief valve with return line must be inserted in the reservoir.
- A separate pressure relief valve with return line to the reservoir must be foreseen, if a partial discharge flow has to be drained over a prolonged period.

Direction of rotation:

The following should be noted for direction of rotation:

- when looking at the pump shaft end, the direction of pumping is from left to right if the shaft rotates **clockwise**.
- when looking at the pump shaft end, the direction of pumping is from right to left if the shaft rotates **counterclockwise**.

without pressure relief valve

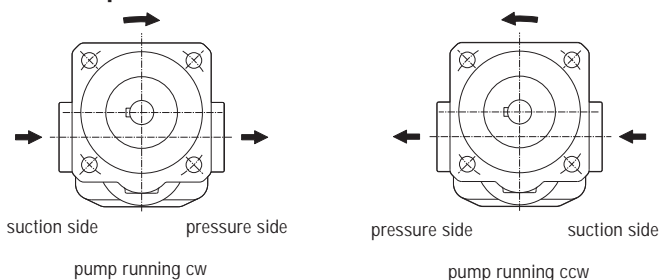

with pressure relief valve

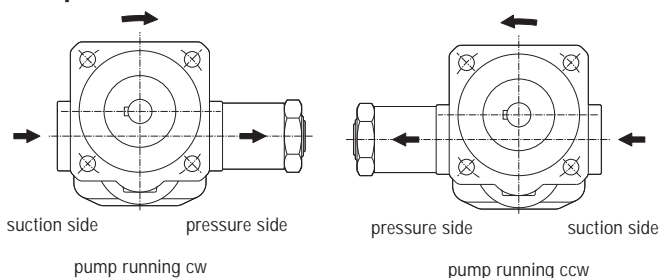

Characteristics

14 Nominal displacement sizes
 $4 \dots 80 \text{ cm}^3 \quad V_g = 4/5/6.3/8/10/12.5/16/20/25 \text{ cm}^3$
 $32/40/50/63/80 \text{ cm}^3$

Direction of rotations: **cw or ccw**
cw and ccw
 Mounting type: flange DIN ISO 3019
 Drive shaft end: ISO R 775 short/cyl.

Operating pressure

Suction side

$p_{e \text{ min}}$: -0.4 bar (vacuum)
 briefly on startup -0.6 bar
 with universal model restriction $p_{e \text{ min}}$
 $p_{e \text{ max}}$: 1 bar for NBR- and FPM rotary shaft lip-type seal
 2 bar for PTFE-lip-type seal
 10 bar for mechanical seal
 (higher pressures on request)

Pipe connection

Nominal size 4...25: Whitworth pipe thread
 Nominal size 32...80: SAE flange

Fluid temperature

$\vartheta_{m \text{ min}}$ = -10°C
 $\vartheta_{m \text{ max}}$ = 90°C for NBR lip-type shaft seal
 = 150°C for FPM lip-type shaft seal
 = 200°C for PTFE lip-type seal

Pressure side

p_n = 25 bar (higher pressures on request)

= 150°C for GLRD with FPM aux. seals
 = 200°C for GLRD with PTFE aux. seals

Speed of rotations

Nominal size 4...80 200...3000 1/min

Ambient temperature ϑ_u = -20...60 °C

Viscosity

(dependent on pressure and speed of rotations) $\nu = 12 \dots 20,000$

Mounting position: optional
 (for exception, see Universal unit)

Discharge flow: see Table page 7
 Drive power: see Table page 7 and 8

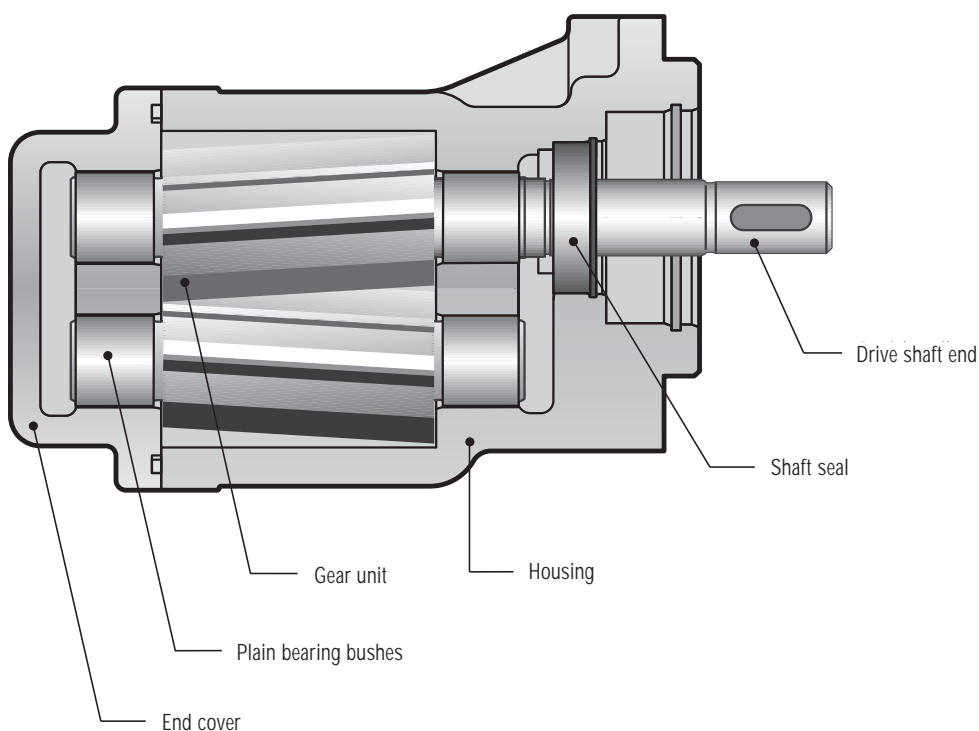

Technical Data

Type Code

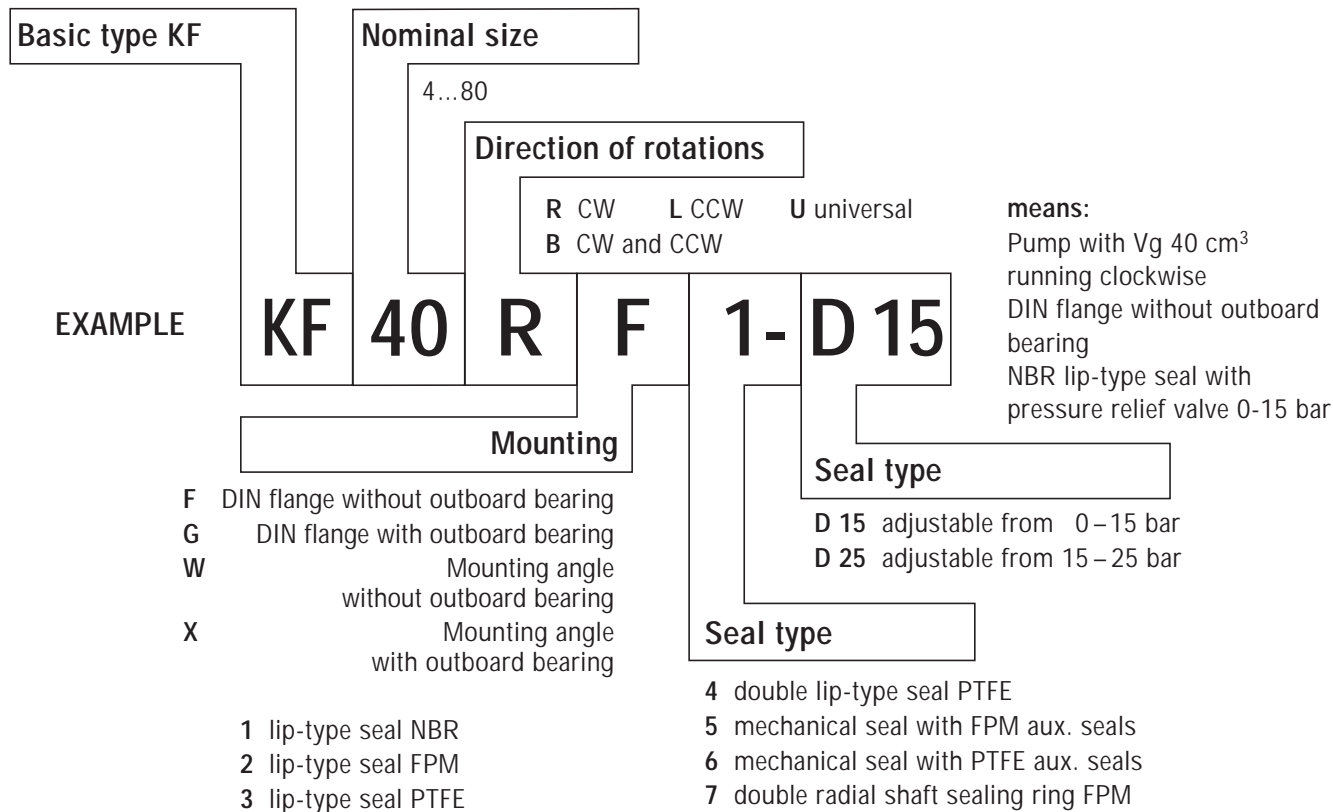

Nominal size	Geometrical displacemt V _g cm ³	Operating pressure p _b bar	Maximum pressure p _{max} bar	Speed range		Permissible load (n=1500 1/min) F _{radial} N	Remark
				n _{min} 1/min	n _{max} 1/min		
4	4.03	25	40	200	3000	700	Operating pressure p _b = perm. sustained pressure Permissible load only for version with outboard bearing. F _{radial} at centre of shaft end. For certain operating conditions, the minimum or maximum characteristics should not be used. For example, the max. operating pressure is not permissible in combination with low speed and low viscosity. In such limit ranges, please consult us.
5	5.05						
6	6.38						
8	8.05						
10	10.11						
12	12.58						
16	16.09						
20	20.1						
25	25.1						
32	32.12	25	40	200	3000	1500	
40	40.21						
50	50.2						
63	63.18						
80	80.5						

Power Consumption

Table 1 Speed n = 950 1/min

	Pressure p _b in bar								Nominal size	Pressure p _b in bar								Power consumption P in KW
	2	4	6	8	10	15	20	25		2	4	6	8	10	15	20	25	
	Discharge flow Q in l/min	3.7	3.6	3.6	3.5	3.4	3.3	3.1		2.9	4	0.04	0.05	0.07	0.08	0.09	0.13	
	4.6	4.5	4.5	4.4	4.3	4.1	3.8	3.6	5	0.04	0.06	0.08	0.10	0.11	0.16	0.20	0.25	
	5.8	5.7	5.6	5.5	5.4	5.1	4.9	4.6	6	0.05	0.07	0.09	0.12	0.14	0.19	0.25	0.30	
	7.3	7.2	7.1	7.0	6.8	6.5	6.2	5.8	8	0.06	0.09	0.11	0.14	0.17	0.24	0.31	0.38	
	9.2	9.0	8.9	8.7	8.6	8.2	7.7	7.3	10	0.07	0.10	0.14	0.17	0.21	0.29	0.38	0.47	
	11.4	11.3	11.1	10.9	10.7	10.2	9.6	9.1	12	0.08	0.12	0.16	0.21	0.25	0.36	0.47	0.58	
	14.6	14.4	14.2	13.9	13.7	13.1	12.4	11.7	16	0.09	0.15	0.20	0.26	0.31	0.45	0.60	0.74	
	18.2	18.0	17.7	17.4	17.1	16.3	15.5	14.7	20	0.10	0.18	0.25	0.32	0.39	0.56	0.74	0.92	
	22.8	22.4	22.1	21.7	21.3	20.4	19.4	18.3	25	0.12	0.21	0.30	0.39	0.48	0.70	0.92	1.14	
	29	29	28	28	27	26	25	23	32	0.2	0.3	0.4	0.5	0.6	0.9	1.2	1.5	
	37	36	36	35	34	33	31	29	40	0.2	0.4	0.5	0.6	0.8	1.1	1.5	1.8	
	46	45	44	43	43	41	38	36	50	0.3	0.5	0.6	0.8	1.0	1.4	1.9	2.3	
	58	57	56	55	54	51	48	45	63	0.4	0.6	0.8	1.0	1.2	1.8	2.4	2.9	
	73	72	71	69	68	65	61	58	80	0.4	0.7	1.0	1.3	1.6	2.3	3.0	3.7	

Table 2 Speed n = 1450 1/min

	Pressure p _b in bar								Nominal size	Pressure p _b in bar								Power consumption P in KW
	2	4	6	8	10	15	20	25		2	4	6	8	10	15	20	25	
	Discharge flow Q in l/min	5.7	5.6	5.6	5.5	5.4	5.3	5.1		4.9	4	0.06	0.08	0.10	0.12	0.15	0.20	
	7.1	7.1	7.0	6.9	6.8	6.6	6.4	6.1	5	0.07	0.10	0.12	0.15	0.18	0.24	0.31	0.38	
	9.0	8.9	8.8	8.7	8.6	8.3	8.0	7.8	6	0.08	0.11	0.15	0.18	0.21	0.30	0.38	0.47	
	11.3	11.2	11.1	11.0	10.9	10.5	10.2	9.8	8	0.09	0.14	0.18	0.22	0.26	0.37	0.47	0.58	
	14.2	14.1	14.0	13.8	13.6	13.2	12.8	12.4	10	0.11	0.16	0.21	0.27	0.32	0.45	0.58	0.72	
	17.7	17.6	17.4	17.2	17.0	16.5	15.9	15.4	12	0.12	0.19	0.26	0.32	0.39	0.55	0.72	0.89	
	22.6	22.4	22.2	22.0	21.7	21.1	20.5	19.8	16	0.16	0.26	0.37	0.47	0.57	0.82	1.08	1.33	
	28.3	28.0	27.7	27.4	27.1	26.4	25.6	24.7	20	0.17	0.28	0.39	0.49	0.60	0.87	1.14	1.41	
	35.3	35.0	34.6	34.3	33.9	32.9	31.9	30.9	25	0.20	0.34	0.47	0.61	0.74	1.08	1.41	1.75	
	45	45	44	44	43	42	40	39	32	0.3	0.5	0.7	0.8	1.0	1.4	1.9	2.3	
	56	56	55	55	54	52	50	49	40	0.4	0.6	0.9	1.1	1.3	1.8	2.3	2.9	
	70	70	69	68	67	65	63	61	50	0.5	0.8	1.1	1.3	1.6	2.3	2.9	3.6	
	89	88	87	86	85	82	79	77	63	0.7	1.0	1.3	1.7	2.0	2.9	3.7	4.5	
	113	112	111	109	108	105	101	98	80	0.8	1.2	1.7	2.1	2.5	3.6	4.7	5.8	

The ratings refer to a mineral oil with a viscosity of 34 mm²/s.

Margin of error for the flow Q +2,5%...-5% of the tabular value.
For viscosity < 30 mm²/s, take a reduction of the rated flow Q into account.

The output of the drive motor should be selected 20% higher than tabular value P.

For viscosity > 100 mm²/s, an increase in the required power is necessary, in this case proceed as per description on page 8.

Power consumption

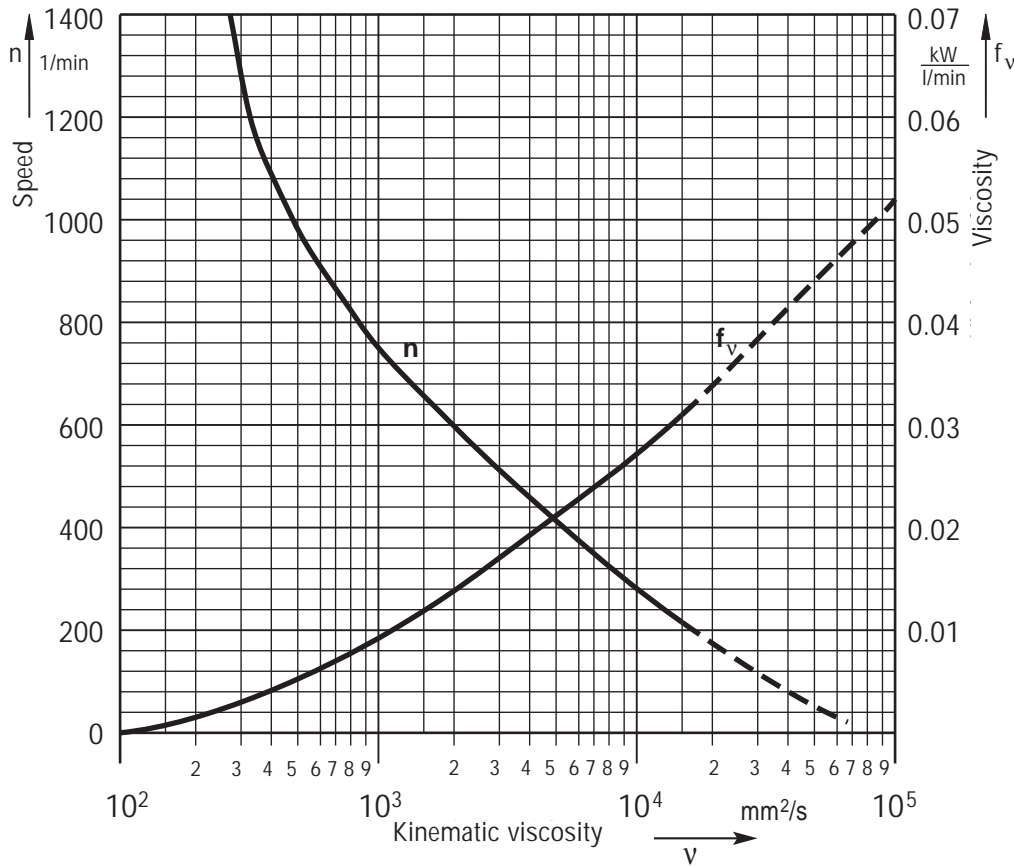

Diagram: $n, f_v = f(v)$

Note:
 To determine the power consumption, always the max. operating viscosity at starting state.
 The power of the drive motor should be selected 20% higher than the value determined.

Calculation of power consumption

$$P_{1Pu} = P_{tab} \cdot \frac{n}{1450} + f_v \cdot Q$$

P_{1Pu} = pump power consumption (kW)
 P_{tab} = power consumption per table (kW)
 n = speed (1/min)
 dependent on viscosity!
 f_v = viscosity factor $\left[\frac{\text{kW}}{\text{l/min}} \right]$
 see diagram
 $Q = \frac{V_g \cdot n}{1000}$ = discharge flow (l/min) where $Q = \frac{V_g \cdot n}{1000}$
 V_g = geometrical displacement (cm³)

Example: Pump-type KF 80

Viscosity	$v = 3000 \text{ mm}^2/\text{s}$
Operating pressure at	$p = 15 \text{ bar}$
	$P_{tab} = 3.6 \text{ kW}$
	$n = 500 \text{ 1/min}$
	$f_v = 0,017 \frac{\text{kW}}{\text{l/min}}$
	$Q = 40 \text{ l/min}$

becomes

$$P_{1pu} = \left(3.6 \cdot \frac{500}{1450} + 0.017 \cdot 40 \right) \text{ kW}$$

$$P_{1Pu} = 1.92 \text{ kW}$$

Motor power output: $P_{2Mot} = 1.2 \cdot P_{1Pu} = 2.3 \text{ kW}$
 Select helical geared motor with $P = 3.0 \text{ kW}$
 $n = 500 \text{ 1/min}$

Conversion factors

$1 \text{ bar} \hat{=} 14.5 \frac{\text{lb}}{\text{in}^2} = 14.5 \text{ psi}$
 $1 \frac{\text{l}}{\text{min}} \hat{=} 4.546 \frac{\text{gal}}{\text{min}} = [\text{U.K.}]$
 $1 \frac{\text{l}}{\text{min}} \hat{=} 3.785 \frac{\text{gal}}{\text{min}} = [\text{US}]$

Speed recommendation

Kinematic viscosity $v \text{ mm}^2/\text{s}$										
< 300	300	500	1000	2000	3000	6000	10000	20000	30000	
≥ 1500	1250	1000	750	600	500	400	300	200	100	
Speed $n_{max} \text{ 1/min}$										

Flange-mounting pump

KF 4...25 Flange-mounting version

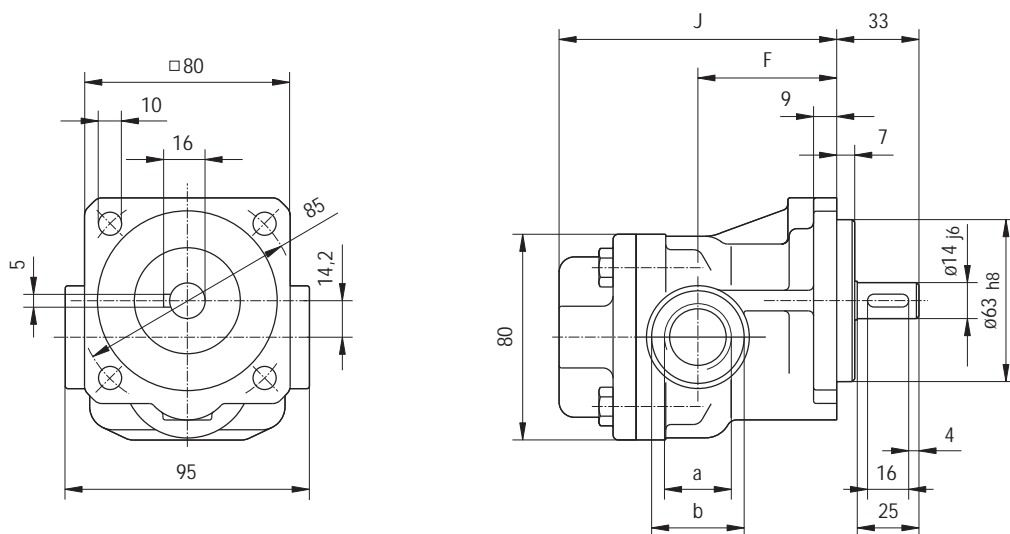

KF 4...25 Flange-mounting version with pressure relief valve

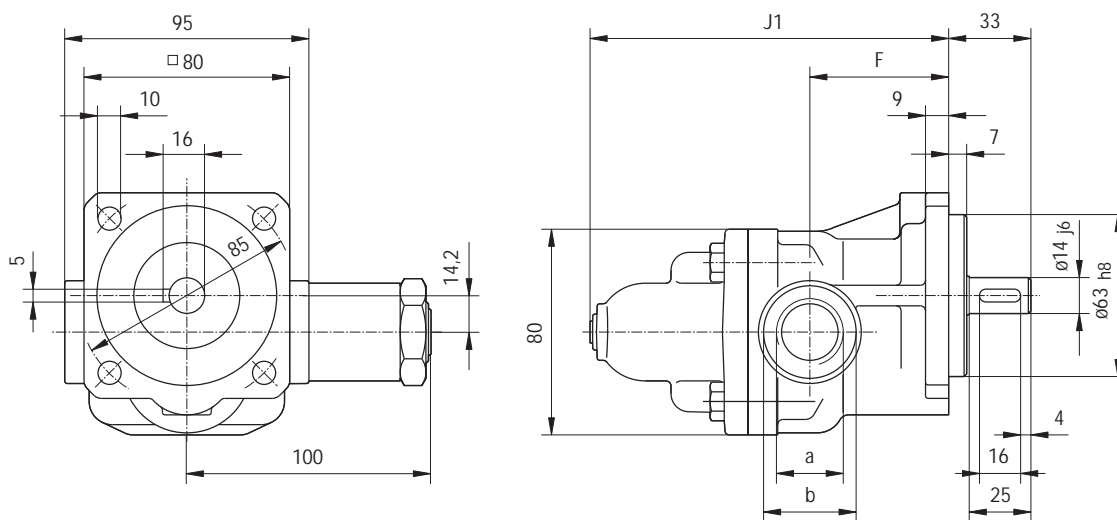

Nominal size	Suction and pressure connection		F	J	J ₁	Weight in kg	
	a	b				without pressure relief	with pressure relief
4...12	G 3/4 17 deep	36	54	109	140	2.9	3.7
16...25	G 1 19 deep	42	63	131	162	3.5	4.3

Flange-mounting pump

KF 32...80 Flange-mounting version

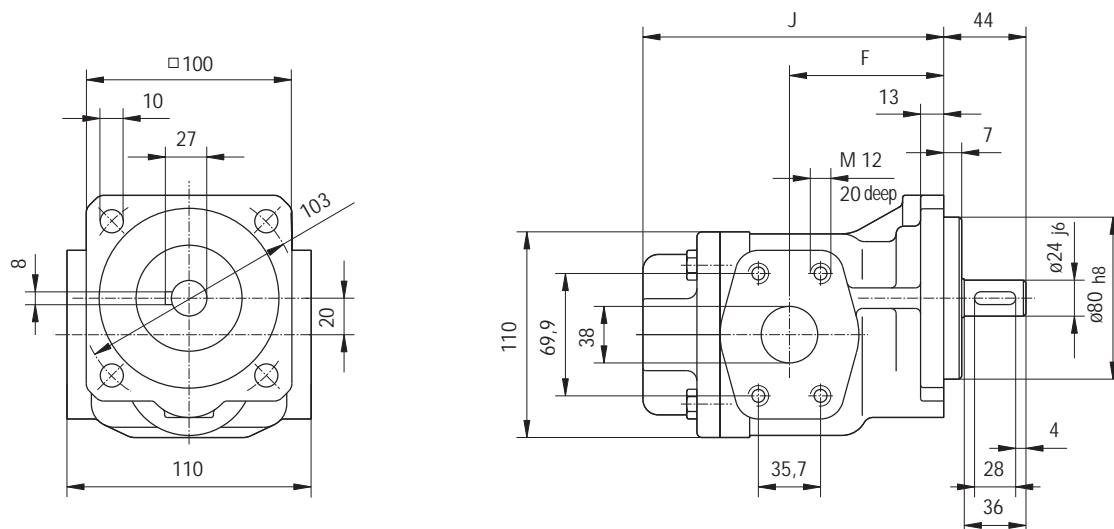

KF 32...80 Flange-mounting version with pressure relief valve

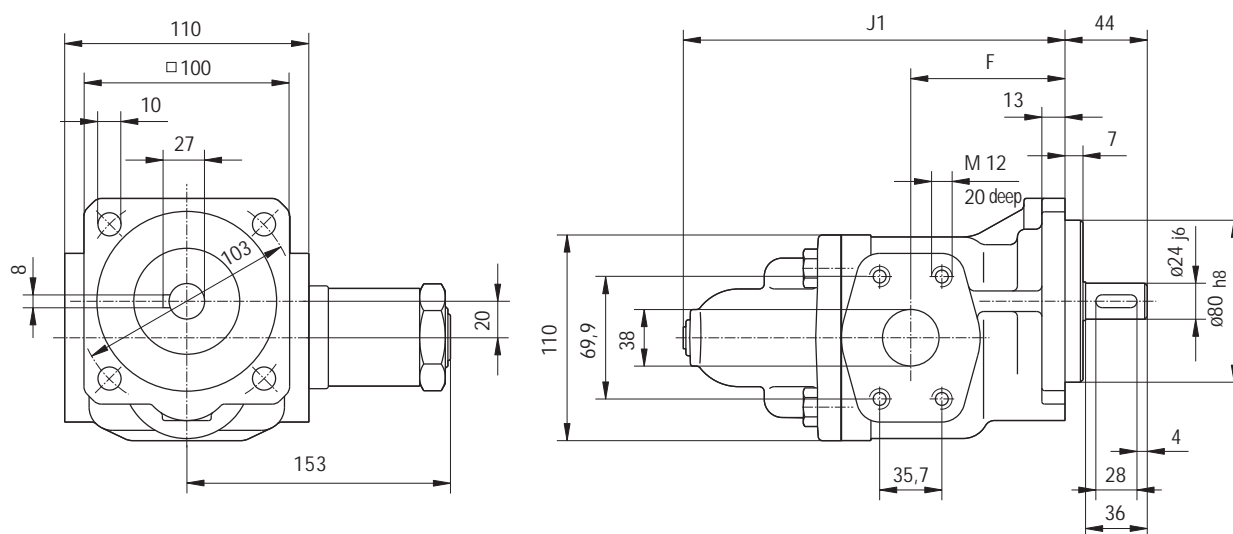

Nominal size	F	J	J ₁	Weight in kg	
				without pressure relief	with pressure relief
32...50	84	171	212	7.7	9.5
63...80	100	206	247	9.4	11.2

Foot mounted pump

KF 4...25 Foot mounted version

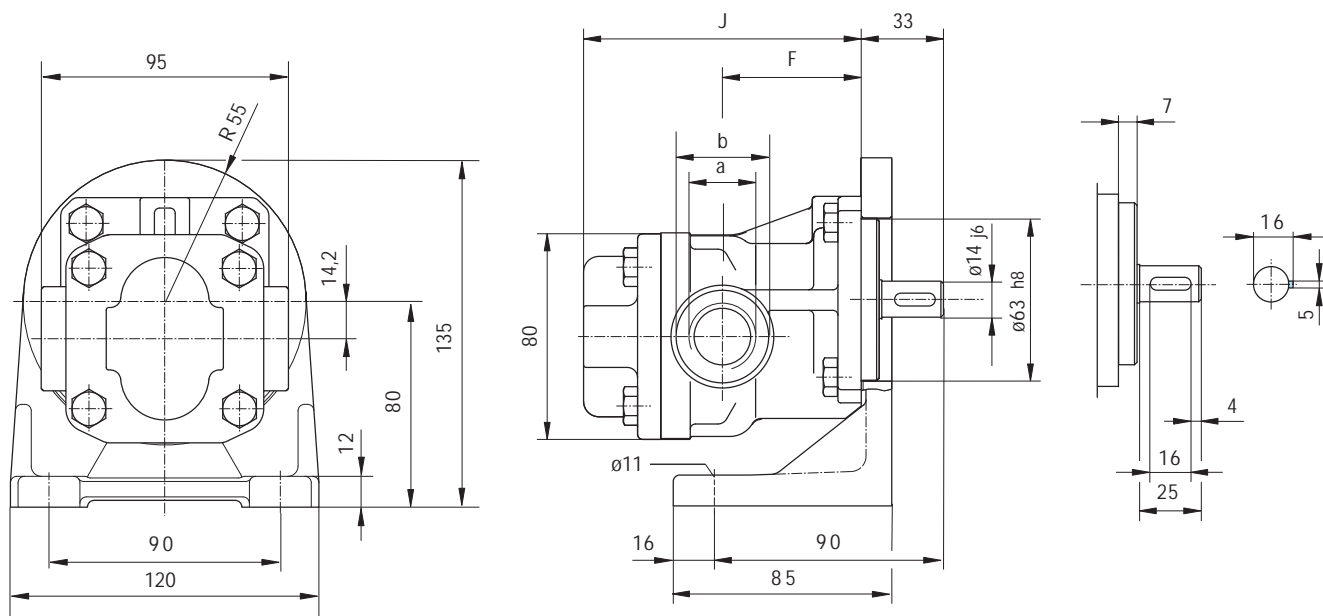

KF 4...25 Foot mounted version with pressure relief value

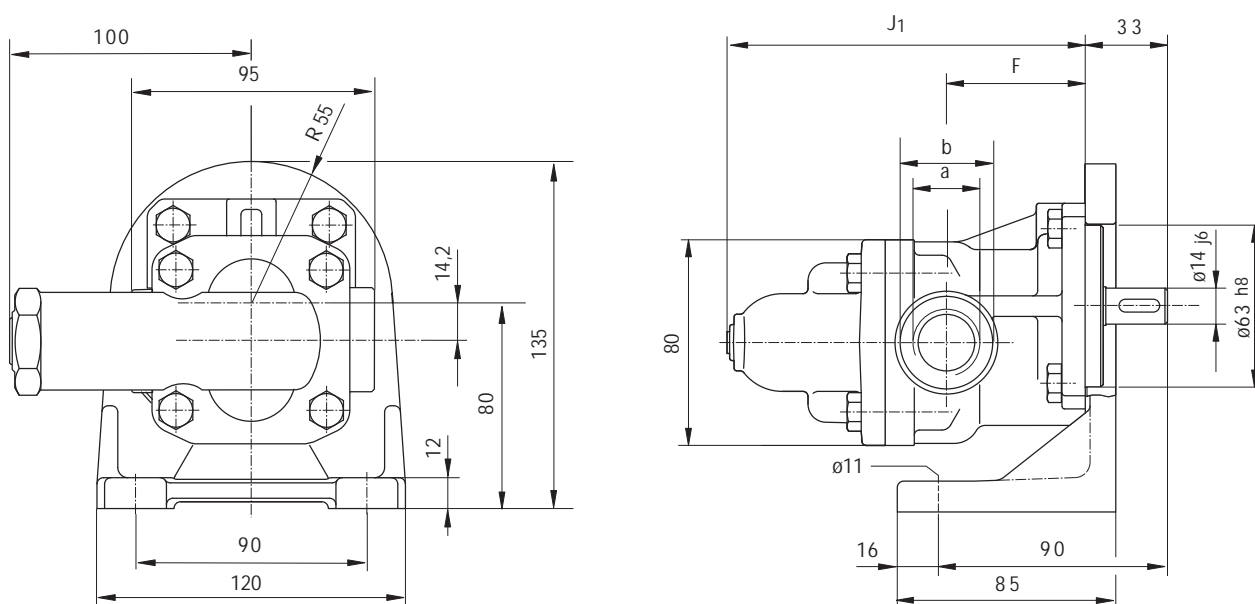

Nominal size	Sucture and pressure connection		F	J	J ₁	Weight in kg	
	a	b				without pressure relief	with pressure relief
4...12	G 3/4 17 deep	36	54	109	140	4.2	5
16...25	G 1 19 deep	42	63	131	162	4.8	5.6

Accessorie: Couplings

Version A

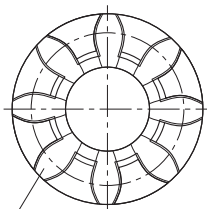
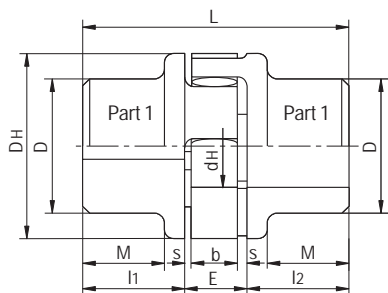

Serrated collar of polyurethane (Vulkollan) Shore hardness 92° Colour: natural

Version B

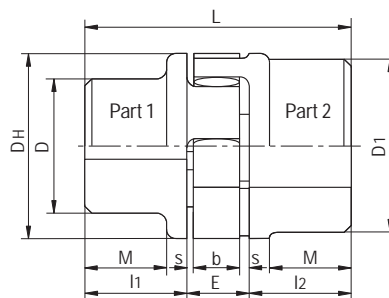

Version A

Version B

Ordering code	Coupling size	Hub material (AL)		Rough bore		Finished bore		Dimensions											
		Weight kg	Mertia moment kgm ²	part 1	part 2	min.		max.		l1/l2	E	s	b	L	M	DH	D	D ₁	dh
						part 1	part 2	part 1	part 2										
RA 19-Z 25/..-Z 25/..	19	0.117	0.00003	4	-	6	-	19	-	25	16	2	12	66	20	40	32	-	18
RA 24-Z 30/..-Z 30/..	24	0.24	0.00008	6	-	8	-	24	-	30	18	2	14	78	24	55	40	-	27
RA 28-Z 35/..-Z 35/..	28	0.39	0.0002	8	-	10	-	28	-	35	20	2.5	15	90	28	65	48	-	30
RA 38-Z 45/..-Z 45/..	38	0.82	0.0007	10	-	12	-	38	-	45	24	3	18	114	37	80	66	-	38
RA 19/24-Z 25/..-Z 25/..	19/24	0.129	0.00004	4	17	6	19	19	24	25	16	2	12	66	20	40	32	40	18
RA 24/28-Z 30/..-Z 30/..	24/28	0.26	0.0001	6	22	8	24	24	28	30	18	2	14	78	24	55	40	48	27
RA 28/38-Z 35/..-Z 35/..	28/38	0.46	0.0003	8	26	10	28	28	38	35	20	2.5	15	90	28	65	48	65	30
RA 38/45-Z 45/..-Z 45/..	38/45	0.89	0.0008	10	36	12	38	38	45	45	24	3	18	114	37	80	66	76	38

Type Code KF coupling

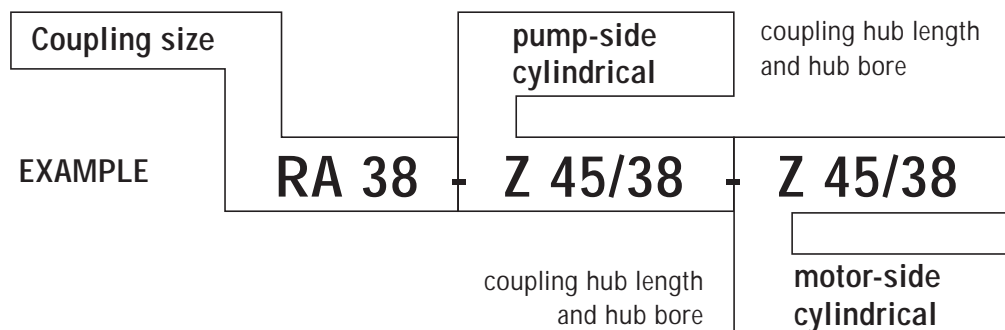

Operating temperature:
-10 °C to +80 °C (short duration temperature peaks up to 120°C are permissible).

Weights and mass moments of inertia refer to max. finish-machined bore without slot.

Finish-machined bores to ISO Fit H7, parallel key slots in accordance with DIN 6886 Sh.1.

Motor-Pump Assemblies

KF 4...25 Motor with pump

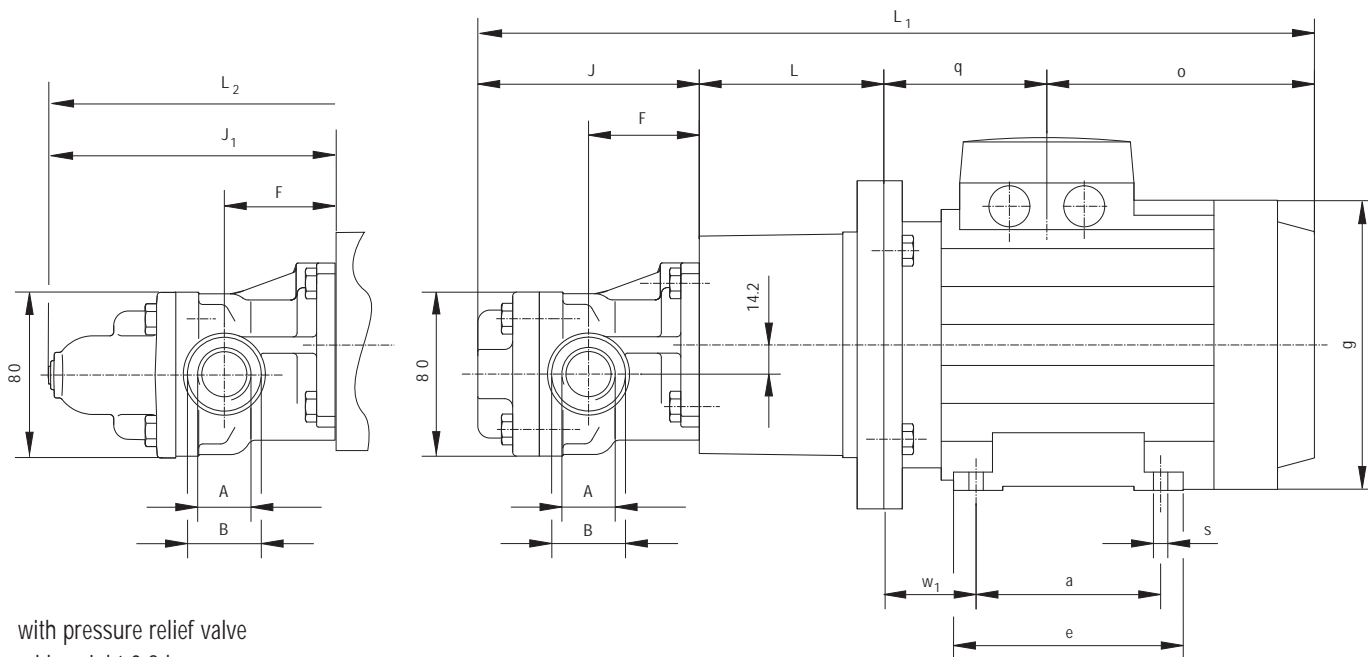

with pressure relief valve
add. weight 0.8 kg

Frame size	Power		Speed		Bell housing	Coupling	Total weight kg	
	kW	1/min	kW	1/min			Nominal size	
	Motor 6 pole		Motor 4 pole				4...12	16...25
71 s	0.18	920	0.25	1400	PT160-A-063-80	RA19-Z25/14-Z25/14	10	10.5
71	0.25	920	0.37	1410			11	11.5
80 s	0.37	920	0.55	1420	PT200-A-063-100	RA19-Z25/14-Z25/19	13.5	14
80	0.55	930	0.75	1420			14.5	15
90 S	0.75	930	1.1	1410	PT200-A-063-100	RA19/24-Z25/14-Z25/24	17.5	18
90 L	1.1	930	1.5	1420			20.5	21
100 LS	-	-	2.2	1430	PT250-A-063-120	RA24/28-Z30/14-Z30/28	26.5	27
100 L	1.5	950	3	1430			29.5	30
112 M	2.2	940	4	1435			32.5	33

KF 4...25 Pump sizes

Nominal size	Suction and pressure connection		F	J	J ₁
	A	B			
4...12	G 3/4 17 deep	36	54	109	140
16...25	G 1 19 deep	42	63	131	162

Motor-Pump Assemblies

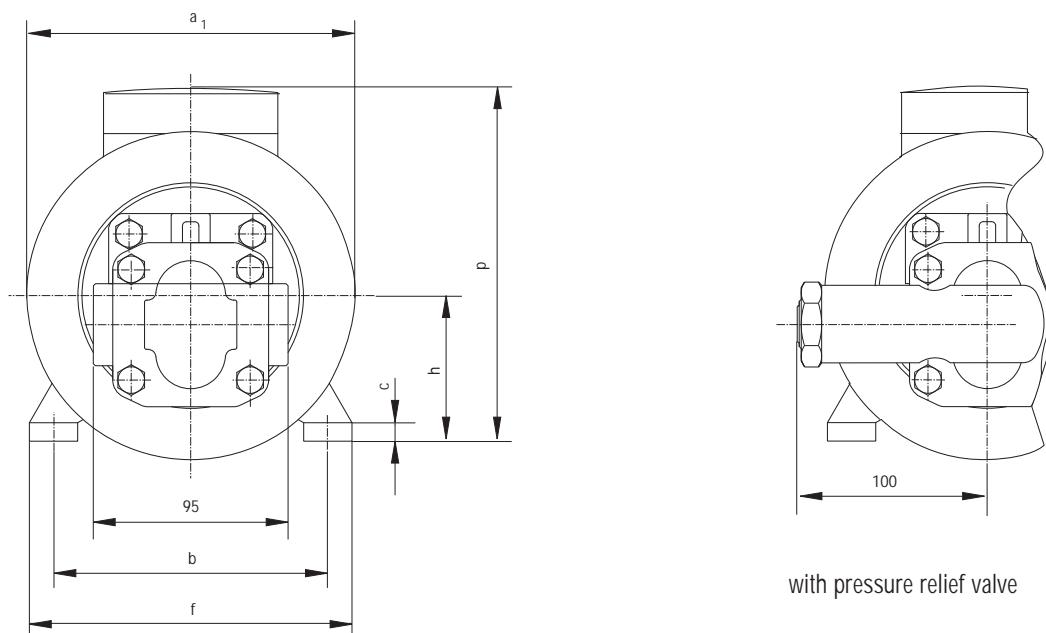

Frame size	4...12 16...25		4...12 16...25		4 - 25													
	L ₁	L ₁	L ₂	L ₂	L	a ₁	a	b	c	e	f	g	h	o	p	q	s	w ₁
71 s	399	421	430	452	80	160	90	112	9	112	136	140	71	130	172	80	7	45
71	399	421	430	452	80	160	90	112	9	112	136	140	71	130	172	80	7	45
80 s	441	463	472	494	100	200	100	125	10	125	154	158	80	139	192	94	10	50
80	441	463	472	494	100	200	100	125	10	125	154	158	80	139	192	94	10	50
90 S	454	476	485	507	100	200	100	140	10	125	170	178	90	151	212	94	10	56
90 L	479	501	510	532	100	200	125	140	10	150	170	178	90	177	212	94	10	56
100 LS	527	549	558	580	120	250	140	160	12	172	197	198	100	201	236	97	12	63
100 L	527	549	558	580	120	250	140	160	12	172	197	198	100	201	236	97	12	63
112 M	530	552	561	583	120	250	140	190	12	168	222	221	112	161	258	140	12	70

Note:

All pump and Motor sizes can be combined.

Motor frame sizes are based on ABB. Other manufactures motors can be supplied on request as IM B35.

Motor-Pump Assemblies

KF 32...80 Motor with pump

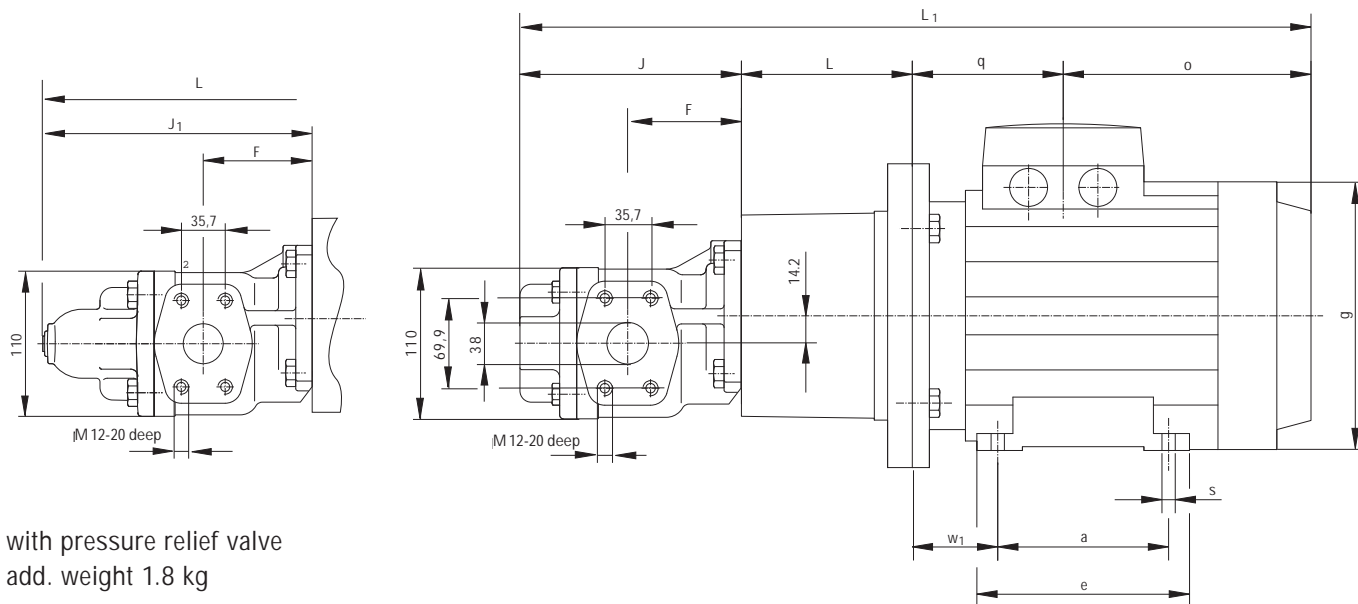

with pressure relief valve
add. weight 1.8 kg

Frame size	Power		Speed		Bell housing	Coupling	Total weight kg	
	kW	1/min	kW	1/min			Nominal size	32...50
	Motor 6 pole		Motor 4 pole					
80 s	0.37	920	0.55	1420	PT200-A-080-100	RA19/24-25/24-/Z25/19	18.4	20.1
80	0.55	930	0.75	1420			19.4	21.1
90 S	0.75	930	1.1	1410	PT200-A-080-110	RA24-Z30/24-Z30/24	22.3	24
90 L	1.1	930	1.5	1420			25.3	27
100 LS	-	-	2.2	1430	PT250-A-080-124	RA24/28-Z30/24-Z30/28	31.3	33
100 L	1.5	950	3	1430			34.3	36
112 M	2.2	940	4	1435			37.3	39
132 S	3	960	5.5	1450	PT300-A-080-144	RA28/38-Z35/24-Z35/38	50	52
132 M	4	960	7.5	1450			58	60
132 M	5.5	955	-	-			64	66
160 M	7.5	9975	11	1455	PT350-A-080-188	RA38/45-Z45/24-Z45/42	91	93
160 L	11	970	15	1460			105	107

KF 32...80 Pump sizes

Nominal size	F	J	J ₁
	32...50	84	171
63...80	100	206	247

Motor-Pump Assemblies

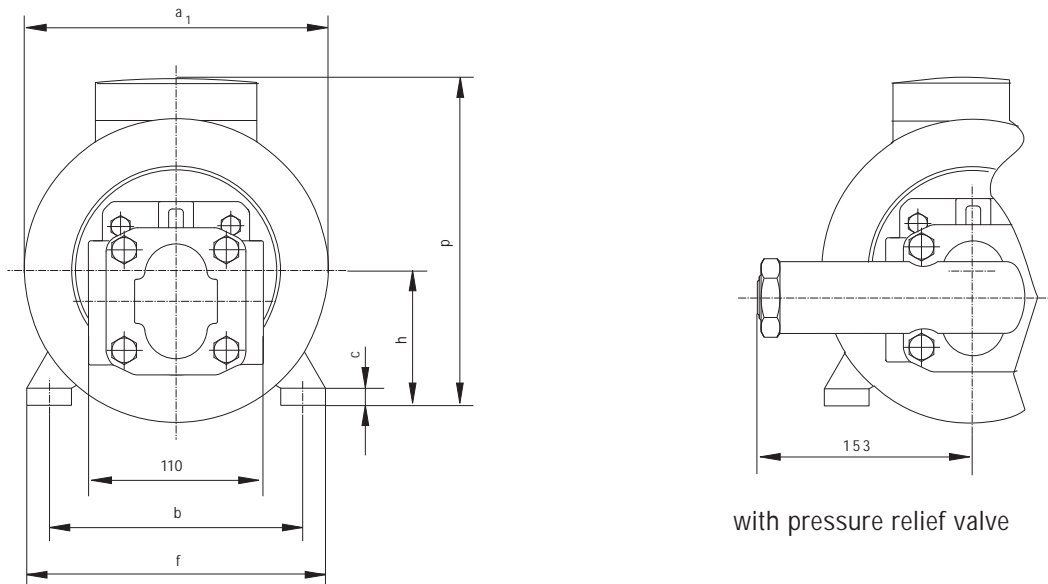

Frame size	32...50 63...80		32...50 63...80		32 - 80														
	L ₁	L ₁	L ₂	L ₂	L	a ₁	a	b	c	e	f	g	h	o	p	q	s	w ₁	
80 s	504	539	545	580	100	200	100	125	10	125	154	158	80	139	192	94	10	50	
80	504	539	545	580	100	200	100	125	10	125	154	158	80	139	192	94	10	50	
90 S	526	561	567	602	110	200	100	140	10	125	170	178	90	151	212	94	10	56	
90 L	552	587	593	628	110	200	125	140	10	150	170	178	90	177	212	94	10	56	
100 LS	593	628	643	669	124	250	140	160	12	172	197	198	100	201	236	97	12	63	
100 L	593	628	643	669	124	250	140	160	12	172	197	198	100	201	236	97	12	63	
112 M	596	631	637	672	124	250	140	190	12	168	222	221	112	161	258	140	12	70	
132 S	682	717	723	748	144	300	140	216	14	212	262	261	132	216	296	151	12	89	
132 M	682	717	723	748	144	300	178	216	14	212	262	261	132	216	296	151	12	89	
132 M	682	717	723	748	144	300	178	216	14	212	262	261	132	216	296	151	12	89	
160 M	845	880	886	921	188	350	210	254	18	292	312	316	160	344	370	142	15	108	
160 L	845	880	886	921	188	350	254	254	18	292	312	316	160	344	370	142	15	108	

Note:

All pump and Motor sizes can be combined.

Motor frame sizes are based on ABB. Other manufactures motors can be supplied on request as IM B35.

Accessorie: Connections

Bolt-on flange

G-SAE 1 1/2 - N

Weight 1.2 kg - F

- P

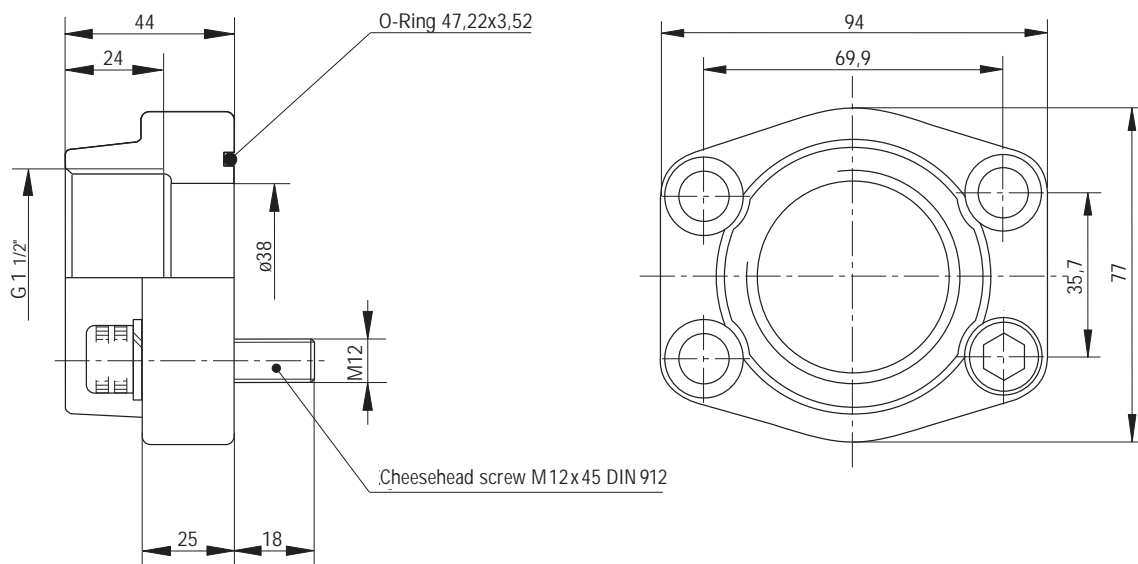

Welding flange

G-SAE 1 1/2 - N

Weight 1.2 kg - F

- P

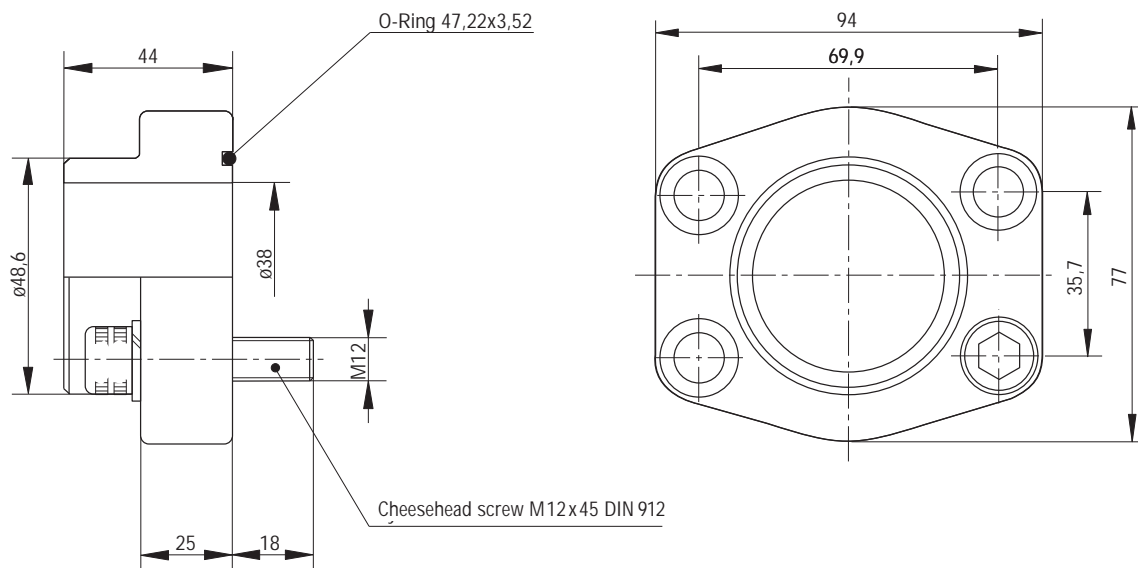

N = NBR -O-Ring

F = FPM -O-Ring

P = PTFE-O-Ring

VOLUTRONIC®

For measurements our tolerance keeps within narrow limits

- VOLUTRONIC®, that means highly dynamic, precise volume and through-flow measurements, evaluated with application orientation, from simple display equipment up to intelligent microcontroller-solutions, from simple flow controls up to complex adjustment.
- The basis for this: The VC-Standard volume meter. A development from our engineers.
- Top international technology which you can rely on.

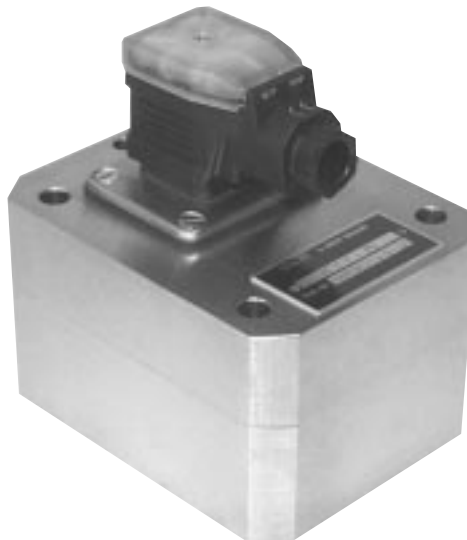

ELECTRONIC

Measure, control, adjust.

- High performance KRACHT Electronics ensure that processes are monitored precisely, adjusted and controlled.
- For example, in process technology as microcontroller for dosage and mixing systems –
- or as compact and robust mobile electronics for hydraulic motors –
- or as future-orientated SPS technology for complete solution with KRACHT Hydraulics Plant –
- or as flexible measuring and recording electronics for differentiated applications in test bed technology.
- KRACHT technology and know-how guarantee functional solutions. Standardised and application-optimised.



Overview of our complete program

Transfer pumps

Transfer pumps for lubricating oil supply equipment, low pressure filling and feed systems, dosing and mixing systems.

Volutronic®

Gear flow meters and electronics for volume and flow metering technology in hydraulics, processing and laquering technology.

Mobile hydraulics

Single and multistage high pressure gear pumps, hydraulic motors and valves for construction machinery, vehicle-mounted machines.

Industrial hydraulics

Cetop directional control and proportional valves, hydraulic cylinders, pressure, quantity and stop valves for pipe and slab construction, hydraulic accessories for industrial hydraulics (mobile and stationary use).

With our decades of experience, we are at your side, world-wide, for the professional mastery of specific applications and complete solutions in hydraulics and process technology.



KF 4-80.e.8.99